



CENTRIFUGAL FANS



Direct Drive Aeration
Series C2000, C2200, C2700,
C3000, C3300

High Speed Direct Drive
CH-2000, CH-2200, CH-2400,
CH-2700, CH-3000

Low Speed Direct Drive
CL-2000, CL-2200, CL-2400,
CL-2700, CL-3000, CL-3300,
CL-3600, CL-4000

High Speed International Direct Drive
CHI-2000, CHI-2200, CHI-2400,
CHI-2700, CHI-3000

Low Speed International Direct Drive
CLI-2200, CLI-2400, CLI-2700,
CLI-3000, CLI-3300,
CLI-3600, CLI-4000

312 SOUTH HWY. 73, PO BOX 398
FALLS CITY, NE 68355-0398
800-500-9777

Index

A Word About Safety	3
Electrical Disconnects	3
Moving Parts.....	3
Air Pressure and Suction	3
Receiving and Inspection	4
Fan Installation.....	4
Handling	4
Storage.....	5
Elevated Units	5
Slab-Mounted Units	6
Startup	7
Procedure.....	7
Fan Maintenance	8
Periodic Fan Maintenance	8
Lubrication Guidelines for WEG™ Motors.....	9
Lubrication Guidelines for Toshiba™ Motors.....	11
Lubrication Guidelines for Baldor™ Motors.....	13
Lubrication Guidelines for Leeson™ Motors.....	14
Wheel Replacement	15
Wheel Balance	16
Fan Rotation/Orientation	17
Common Fan Problems	18
Excessive Vibration	18
Inadequate Performance	18
Excessive Noise	18
Premature Component Failure.....	18
Replacement Parts.....	19
Warranty	20



CAUTION

THIS MACHINE HAS MOVING PARTS THAT CAN CAUSE SERIOUS BODILY INJURY. THE FOLLOWING PRECAUTIONS MUST BE TAKEN BEFORE OPERATING OR PERFORMING MAINTENANCE.

- 1. MAKE SURE ALL MOVING PARTS ARE SHIELDED FROM PERSONNEL AND FALLING OBJECTS.**
- 2. READ THE INSTALLATION AND MAINTENANCE INSTRUCTIONS.**
- 3. DO NOT OPERATE AT SPEEDS OR TEMPERATURES HIGHER THAN PUBLISHED FOR THE SPECIFIC OPERATING CONDITIONS FOR WHICH THE MACHINE WAS PURCHASED.**

A FAILURE TO TAKE THESE PRECAUTIONS COULD RESULT IN SERIOUS BODILY INJURY AND PROPERTY DAMAGE

A Word About Safety

Air moving equipment involves electrical wiring, moving parts, and air velocity or pressure that can create safety hazards if the equipment is not properly installed, operated and maintained. Follow these instructions as well as the additional instructions and warnings on the equipment itself to minimize this danger. Refer to AMCA Publication 410, "Recommended Safety Practices For Air Moving Devices" for additional information.

Electrical Disconnects

Every motor driven fan should have an independent disconnect switch to isolate the unit from the electrical supply. The switch should be near the fan and must be capable of being locked out by maintenance personnel while servicing the unit in accordance with OSHA procedures.

Moving Parts

All moving parts must have guards to protect personnel. Safety requirements vary, so the number and type of guards needed to meet company, local and OSHA standards must be determined and specified by the user. Never start a fan without having all safety guards installed. Check regularly for damaged or missing guards and do not operate any fan with guards removed. Fans can also become dangerous because of potential "windmilling," even though all electrical power is disconnected. Always block the rotating assembly before working on any moving parts.

Air Pressure and Suction

Fans present a hazard from the suction created at the fan inlet in addition to the normal dangers of rotating machinery. This suction can draw materials into the fan where they become high velocity projectiles at the outlet. Suction can also be extremely dangerous to persons in close proximity to the inlet, as the forces involved can overcome the strength of most individuals. Inlets and outlets that are not ducted should be screened to prevent entry and discharge of solid objects.

Receiving and Inspection

The fan and accessories should be inspected on receipt for any shipping damage. Remove safety wire from wheel before attempting to start. Turn the wheel by hand to see that it rotates freely and does not bind. If dampers or shutters are provided, check these accessories for free operation of all moving parts.

FOB factory shipping terms require that the receiver be responsible for inspecting the equipment upon arrival. Note damage or shortages on the Bill of Lading and file any claims for damage or loss in transit. AIRLANCO will assist the customer as much as possible; however, claims must be originated at the point of delivery.

Fan Installation

AIRLANCO wheels are dynamically balanced when fabricated. Fully assembled fans are test run at operating speeds to check the entire assembly for conformance to AIRLANCO vibration limits. Nevertheless, all units must be adequately supported for smooth operation. **Ductwork or stacks should be independently supported as excess weight may distort the fan housing and cause contact between moving parts.** Duct connections at the fan inlet or outlet should be flexible to isolate the fan from a different duct diameter, from vibration and from noise. Where vibration isolators are used, consult the AIRLANCO certified drawing for proper location and adjustment. Electrical installation shall be in accordance with NFPA 70 "National Electrical Code" and all applicable local codes.

Handling

Fans should only be lifted by the base, mounting supports, or lifting rings. Never lift a fan by the wheel, motor, motor bracket, housing inlet, outlet, or any fan part not designed for lifting. A spreader should always be used to avoid damage.

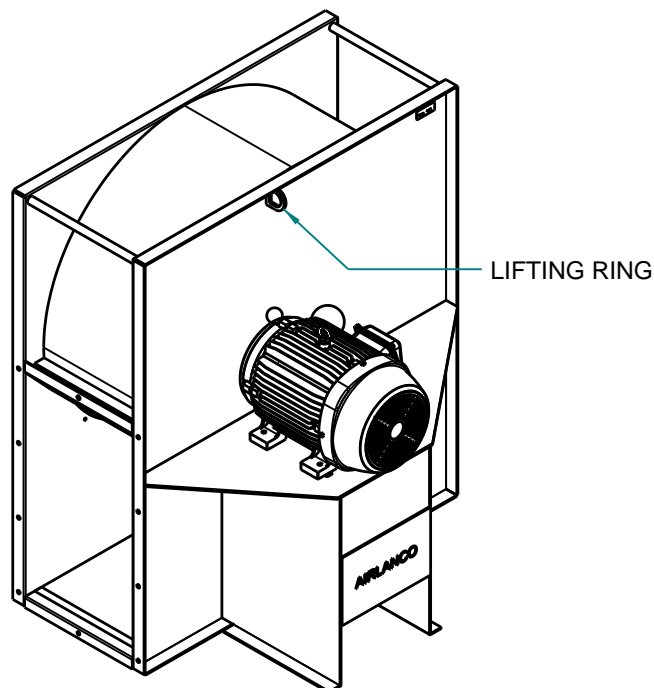

Storage

Check dampers for free operation and lubricate moving parts prior to storage if fan is not to be placed immediately into service. Inspect the stored unit periodically. **Rotate the wheel by hand every two to four weeks to redistribute grease on internal bearing parts.**

Elevated Units

When an elevated or suspended structural steel platform is used, it must have sufficient bracing to support the unit load and prevent side sway. The platform should be of welded construction to maintain permanent alignment of all members.

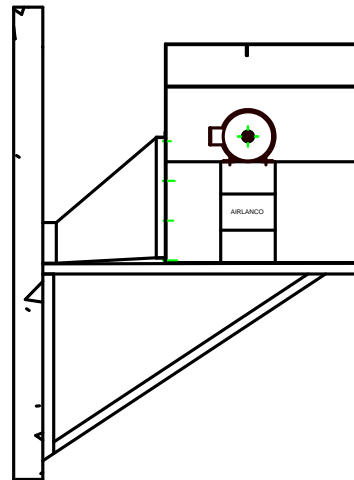

PROPER INSTALLATION

Fan is fully supported by a welded angle iron frame, which is anchored to the concrete bin wall.

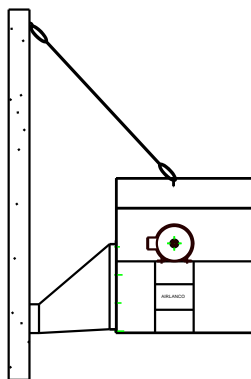

DO NOT hang fan with cables. Lifting rings are for lifting only – not for long term load bearing.

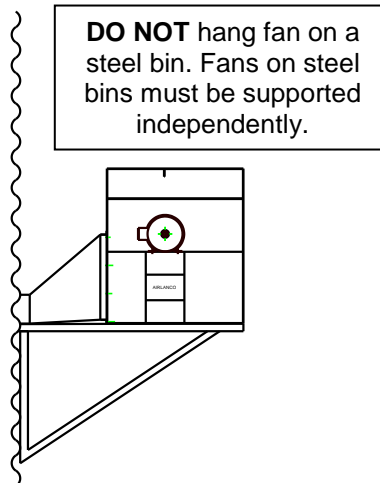

DO NOT hang fan on a steel bin. Fans on steel bins must be supported independently.

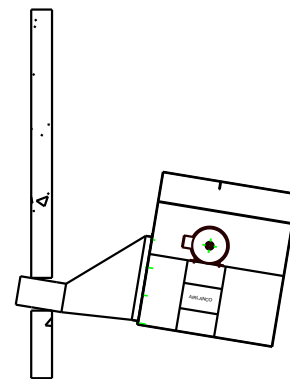

DO NOT attempt to support fan with ducting. Ducting is not designed to be load bearing.

Slab-Mounted Units

A correctly designed and level concrete foundation provides the best means of installing floor-mounted fans. The mass of the base must maintain the fan/driver alignment, absorb normal vibration, and resist lateral loads. The overall dimensions of the concrete base should extend at least six inches beyond the base of the fan. The weight of the slab should be two to four times the weight of the rotating assembly, including the motor. The foundation requires firmly anchored fasteners such as the anchor bolts shown below. Hammer-drilled expansion fasteners can be used in less demanding applications.

Move the fan to the mounting location and lower it over the anchor bolts, leveling the fan with shims around the bolts. Fasten the fan securely.

When grout is used: Shim the fan at least 3/4-inch from the concrete base.

When isolation is used: Check the AIRLANCO certified drawing for installation instructions.

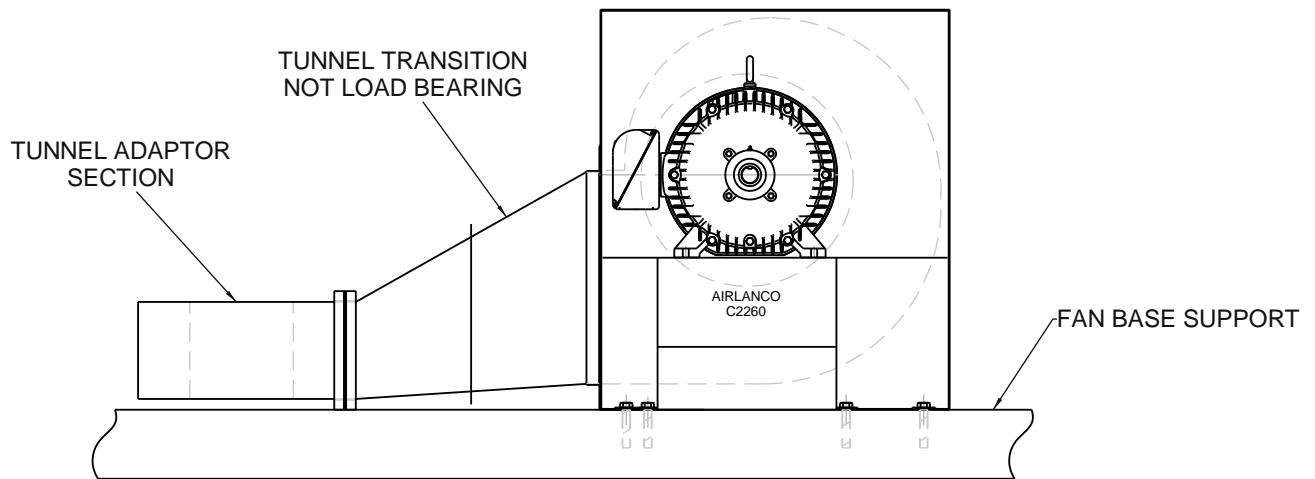

Startup

Safe operation and maintenance includes the selection and use of appropriate safety accessories for the specific installation. This is the responsibility of the customer and requires consideration of equipment location and accessibility as well as adjacent components. All safety accessories must be installed properly prior to start up.

Procedure

1. Inspect the installation prior to starting the fan. Check for any loose items or debris that could be drawn into the fan or dislodged by the fan discharge. Check the interior of the fan as well. Turn the wheel by hand to check for binding.
2. Check the tightness of all nuts and bolts (see Split Taper™ Bushing Information below).
3. Install all remaining safety devices and guards. Verify that the supply voltage is correct and wire the motor. "Bump" the starter to check for proper wheel rotation. See "Fan Orientation/Rotation" page.
4. Use extreme caution when testing the fan with ducting disconnected. Apply power and check for unusual sounds or excessive vibration. If either exists, see the section on **Common Fan Problems**. To avoid motor overload, do not run the fan for more than a few seconds if ductwork is not fully installed. Without the ductwork attached, normal operating speed may not be obtained without motor overload. Once ductwork is attached, check for correct fan speed and complete installation. Ductwork and guards must be fully installed for safety.
5. Bolts and nuts should be rechecked after eight hours and two weeks of operation.

Split Taper™ Bushing Information

AIRLANCO C2000 Series fans use Split Taper™ P1-size bushings, which have a recommended tightening torque of 192 In. Lbs.*

AIRLANCO C2200 Series through C3300 Series fans use Split Taper™ Q1-size bushings, which have a recommended tightening torque of 348 In. Lbs.*

*Divide by 12 to convert to Ft. Lbs.



WARNING: SHUT THE FAN DOWN IMMEDIATELY IF THERE IS ANY SUDDEN INCREASE IN FAN VIBRATION AND/OR NOISE.

Fan Maintenance

AIRLANCO fans are manufactured to high standards with quality materials and components. Proper maintenance will ensure a long and trouble-free service life.

 **WARNING: Do not attempt any maintenance on a fan unless the electrical supply has been completely disconnected and locked. In many cases, a fan can windmill despite removal of all electrical power. The rotating assembly should be blocked securely before attempting maintenance of any kind.**

The key to good fan maintenance is regular and systematic inspection of all fan parts. Inspection frequency is determined by the severity of the application and local conditions. Strict adherence to an inspection schedule is essential.

Periodic Fan Maintenance

1. Check the fan wheel for any wear or corrosion as either can cause catastrophic failures. Check also for the build up of material that can cause unbalance resulting in vibration, bearing wear and serious safety hazards. Clean or replace the wheel as required.
2. Lubricate the motor bearings, but do not over lubricate. See below.
3. During any routine maintenance, all nuts and bolts should be checked for tightness.



Refer to the following pages for motor manufacturer's maintenance guidelines for your particular motor.

Lubrication Guidelines for WEG™ Motors

Reprinted with permission.

It is strongly recommended to grease the machine while it is running. When this is not possible, proceed as follows:

- ✓ Clean the area around the grease fitting.
- ✓ Pump in approximately half of the total required grease, then run the motor for one minute. Then turn off the motor and pump in the balance of the required grease.



The injection of all of the grease when the motor is at a standstill can cause the grease to penetrate into the motor through the inner seal of the bearing housing.

When regreasing, use only special bearing grease that is compatible with Polyrex® EM grease. Polyrex® EM grease is compatible with other types of grease that contain:

- ✓ Lithium base or complex of lithium or polyurea and highly refined mineral oil;
- ✓ Inhibitor additive against corrosion, rust and anti-oxidant additive.

Notes:

- ✓ Although Polyrex® EM is compatible with the types of grease listed above, it is not recommended to mix Polyrex® EM with other greases.
- ✓ If you intend to use a type of grease different than those recommended above, contact WEG prior to use.
- ✓ For special applications (high or low temperatures, speed variation, etc.) the type of grease and relubrication interval are given on an additional nameplate attached to the motor.



Consult WEG™ or the grease manufacturer regarding the use of standard motors for special applications.

WEG™ MOTORS RECOMMENDED RELUBE INTERVAL

HP	FRAME	HOURS		CAPACITY	
		3600 RPM	1800 RPM	GRAMS	OZ.
15	254T	15700	20000	13	0.5
20	256T	15700	20000	13	0.5
25	284T	11500	20000	18	0.6
30	286T	11500	20000	18	0.6
40	324T	9800	20000	21	0.75
50	326T	9800	20000	21	0.75
60	364T	3600	9700	27	0.95
75	365T	3600	9700	27	0.95



WARNING: The table above is specifically intended for relubrication with Polyrex® EM grease, and bearing absolute operating temperature of:

- ✓ 70°C (158°F) for 254/6T to 324/6T frame motors;
- ✓ 85°C (185°F) for 364/5T and larger frame motors.



WARNING: Overgreasing can cause bearing overheating resulting in complete motor failure.

Standard Nameplate for Weg motors.

Reprinted with permission.

Figure 16 - Nameplate position of W22 motors.

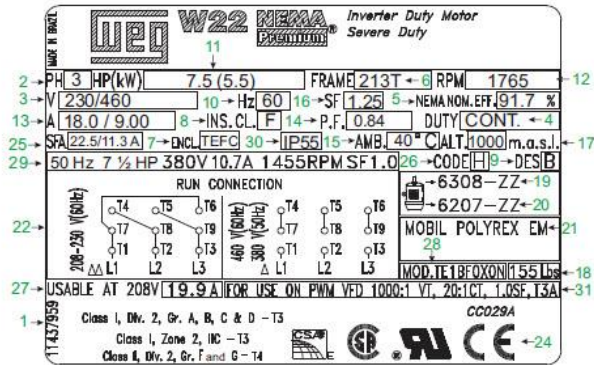

Figure 17 - Nameplate layout for frames 143T to 215T

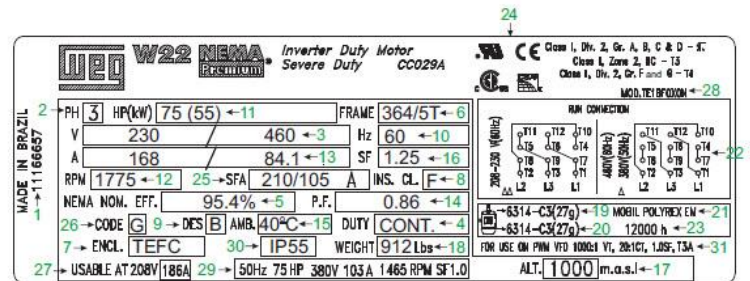

Figure 18 - Nameplate layout for frames 254T to 588/9T

- 1 - Motor code
- 2 - Three-phase
- 3 - Rated operating voltage
- 4 - Service duty
- 5 - Efficiency
- 6 - Frame size
- 7 - Enclosure
- 8 - Insulation class
- 9 - Temperature rise
- 10 - Design
- 11 - Frequency
- 12 - Motor rated power
- 13 - Full load speed (rpm)
- 14 - Rated operating current
- 15 - Power factor
- 16 - Ambient temperature
- 17 - Service factor

- 18 - Altitude
- 19 - Motor weight
- 20 - Drive end bearing specification and amount of grease
- 21 - Non-drive end bearing specification and amount of grease
- 22 - Type of grease for bearings
- 23 - Connection diagram
- 24 - Relubrication intervals in hours
- 25 - Certification labels
- 26 - Service factor current
- 27 - NEMA code letters for locked rotor kVA
- 28 - Current at 208 V
- 29 - Model
- 30 - Derating 50 Hz
- 31 - Degree of protection
- 32 - VFD supply

Motors Without Grease Fittings

Motors up to frame 254/6T do not normally have grease fittings. In these cases, regreasing shall be performed as follows:

- ✓ Carefully disassemble motor.
- ✓ Remove all grease.
- ✓ Wash bearing with kerosene or diesel.
- ✓ Regrease bearing immediately

Lubrication Guidelines for Toshiba™ Motors

Reprinted with permission.

RECOMMENDED GREASES FOR STANDARD APPLICATIONS

Use the following greases listed for the given temperature range, unless otherwise indicated on the motor grease nameplate:

Operating Ambient Temp. -30°C to 50°C	
Chevron SRI	Chevron Products Co.
Exxon Unirex N 2	Exxon Mobil Corp.
Polyrex EM	Exxon Mobil Corp.
Shell Dolium R	Shell Oil Co.
Mobilith SHC 100	Exxon Mobil Corp.

STANDARD SERVICE

1. Select the proper service condition from Table 2.
2. Select the frequency from Table 3 and select the volume from Table 5.
3. Before greasing make sure fittings are clean and free from dirt.
4. Remove relief plug or plate and pump the required amount of grease using a low pressure hand held grease gun.
5. It is important that the machine be relubricated while it is running. Allow the motor to run with the grease outlets open for the following recommended time periods before replacing hardware;
 - 143T to 365T - 20 to 30 minutes
 - 405T and larger - 30 to 60 minutes
6. Used grease may not always come out of the grease outlet when new grease is pumped in. Use the recommended volumes to avoid over-greasing.

Service Conditions	
Standard Duty	Eight hours per day. Light to normal loading. Clean condition, free from dust.
Severe Duty	24 hours per day. Light to normal shock loading, vibration. Exposure to dirt or dusty conditions.
Very Severe Duty	24 hours per day. High ambient temperature. Normal to high shock loading, vibration. Dusty conditions. Confined mounting conditions. Reduce Severe Duty interval by 1/3.

Table 1: Description of Service Conditions

Sync. RPM Range	Frame Size	Type of Service	
		Standard Duty	Severe Duty
3600 - 3000 1800 - 750	143 - 256	8 mo 30 mo	4 mo 12 mo
3600 - 3000 1800 - 750	284 - 365	8 mo 24 mo	4 mo 12 mo
3600 - 3000 1800 - 750	404 - 5811	8 mo 18 mo	4 mo 8 mo

Table 2: Horizontal Motor Lubrication Schedule

Frame Range	Bearing Size	Periodic Grease Amount
143 to 256	6205 / 6206	3 grams
	6207 / 6208 / 6305	5 grams
	6306	10 grams
	6308 / 6309	20 grams
284 to 365	6211	10 grams
	6309	20 grams
	6310 / 6312	30 grams
	6314	50 grams
404 to 5811	6216	20 grams
	6313/NU313 /NU317	30 grams
	NU318 / NU320	50 grams
	6317 / 6318	80 grams
	6320 / 6322 / 6324	80 grams
	NU322 / NU324	80 grams
NU328 / NU228	100 grams	

Table 3: Horizontal Motor Bearing Relubrication Volumes

Lubrication Guidelines for Baldor™ Motors

Reprinted with permission.

Bearing grease will lose its lubricating ability over time, not suddenly. The lubricating ability of a grease (over time) depends primarily on the type of grease, the size of the bearing, the speed at which the bearing operates and the severity of the operating conditions. Good results can be obtained if the following recommendations are used in your maintenance program.

Type of Grease

A high grade ball or roller bearing grease should be used. Recommended grease for standard service conditions is Polyrex® EM. Equivalent and compatible greases include:

- ✓ Texaco Polystar
- ✓ RykonPremium#2
- ✓ Pennzoil Pen 2 Lube
- ✓ Chevron SRI

Relubrication Intervals

Recommended relubrication intervals are shown in the table below. It is important to realize that the recommended intervals are based on average use.

BALDOR™ MOTORS SEVERITY OF SERVICE TABLE

Severity of Service	Hrs/Day of Operation	Ambient Temp. Maximum	Atmospheric Contamination	Relubrication Interval Multiplier
Standard	8	40° C	Clean, Little Corrosion	1.0
Severe	16 Plus	50° C	Moderate dirt, Corrosion	0.5
Extreme	16 Plus	>50° C* or Class H Insulation	Severe dirt, Abrasive dust, Corrosion, Heavy Shock or Vibration	0.1
Low Temperature		<29° C**		1.0

BALDOR™ MOTORS RECOMMENDED RELUBE INTERVAL

HP	FRAME	HOURS		CAPACITY	
		3600 RPM	1800 RPM	GRAMS	OZ.
15	254T	3600	9500	12.5	0.47
20	256T	3600	9500	12.5	0.47
25	284T	2200	7400	17.0	0.61
30	286T	2200	7400	17.0	0.61
40	324T	2200	7400	20.1	0.76
50	326T	2200	7400	20.1	0.76
60	364T	2200	3500	23.0	0.81
75	365T	2200	3500	23.0	0.81

Lubrication Guidelines for Leeson™ Motors

Reprinted with permission.

Motors, properly selected and installed, are capable of operating for many years with a reasonably small amount of maintenance.

Before servicing a motor and motor-operated equipment, disconnect the power supply from motors and accessories. Use safe working practices during servicing of the equipment.

Clean motor surfaces and ventilation openings periodically, preferably with a vacuum cleaner. Heavy accumulations of dust and lint will result in overheating and premature motor failure.

Lubrication Procedure

Motors 10 HP and smaller are usually lubricated at the factory to operate for long periods under normal service conditions without re-lubrication. Excessive or too frequent lubrication may actually damage the motor. Follow instructions furnished with the motor, usually on the nameplate or terminal box cover or on a separate instruction. If instructions are not available, re-lubricate according to the following chart. Use high quality ball bearing grease. Grease consistency should be suitable for the motor's insulation class. For Class B, F or H use a medium consistency polyurea grease such as Shell Dolium R.

If the motor is equipped with lubrication fitting, clean the fitting tip and apply grease gun. Use 1 to 2 full strokes on NEMA 215 frame and smaller motors. Use 2 to 3 strokes on NEMA 254 through NEMA 365 frame. Use 3 to 4 strokes on NEMA 404 frames and larger. For motors that have grease drain plugs, remove the plugs and operate the motor for 20 minutes before replacing the plugs.

For motors equipped with slotted head grease screws, remove the screw and insert a two to three-inch long grease string into each hole on motors in NEMA 215 frame and smaller.

Insert a three to five-inch length on larger motors. For motors having grease drain plugs, remove the plug and operate the motor for 20 minutes before replacing the plugs.

Relubrication Intervals Chart For Motors Having Grease Fittings

Hours of Service Per Year	HP Range	Hours of Relube Value
5000	1/18 to 7 1/2	5 years
	10 to 40	3 years
	50 to 100	1 years
Continuous Normal Applications	to 7 1/2	2 years
	10 to 40	1 years
	50 to 100	9 months
Seasonal Service - Motor is idle for 6 months or more	ALL	1 year (beginning of season)
Continuous high ambient, high vibration or where shaft end is hot	1/8 to 40	6 months
	50 to 150	3 months

Caution: Keep grease clean. Lubricate motors at a standstill. Do not mix petroleum grease and silicone grease in motor bearings.

Wheel Replacement

Proper wheel-to-inlet clearance must be maintained when installing a new wheel. Use the chart below to find the "A" distance, or the distance from the inside of fan wheel back plate to the inside edge of the inlet cone (see illustration). When replacing a fan wheel, make certain that the clearance between the fan wheel and the inlet cone is uniform around the circumference of the fan wheel.

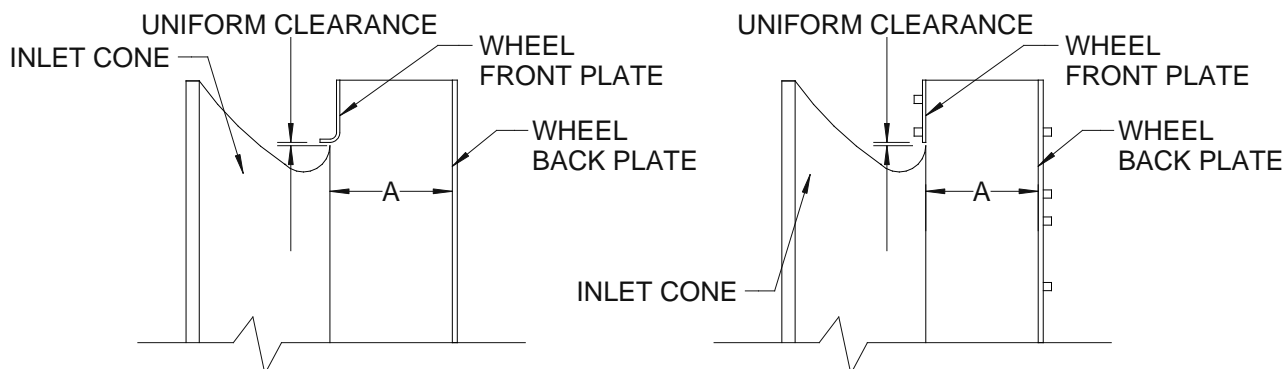

"A" DIMENSION TABLE

Fan Size	Spacing A	Fan Size	Spacing A	Fan Size	Spacing A	Fan Size	Spacing A	Fan Size	Spacing A
C2003	4 1/4	CH-2010	2 3/8	CHI-2003	1 1/2	CL-2003	5	CLI-2203	5 13/16
C2005	1 1/16	CH-2015	3 5/16	CHI-2005	2 1/8	CL-2005	7 13/16	CLI-2205	9 1/16
C2075	1 5/8	CH-2020	4 3/8	CHI-2007	2 15/16	CL-2203	3 5/8	CLI-2403	4 1/8
C2010	2 1/16	CH-2025	5 1/8	CHI-2010	3 3/4	CL-2205	5 3/8	CLI-2405	6 5/16
C2015	3 1/8	CH-2030	16 1/16	CHI-2015	5 1/4	CL-2207	7 13/16	CLI-2407	9 1/4
C2020	4 1/4	CH-2040	7 13/16	CHI-2020	6 13/16	CL-2405	3 7/8	CLI-2705	4 1/2
C2205	4 1/16	CH-2220	3 1/16	CHI-2215	3 3/4	CL-2407	5 7/16	CLI-2707	6
C2215	2 1/16	CH-2225	3 11/16	CHI-2220	4 13/16	CL-2410	7 1/8	CLI-2710	7 15/16
C2220	2 3/4	CH-2230	4 1/4	CHI-2225	5 3/4	CL-2707	3 7/8	CLI-3007	4 1/4
C2225	3 3/8	CH-2240	5 5/16	CHI-2230	6 11/16	CL-2710	4 11/16	CLI-3010	5 1/2
C2230	4	CH-2250	5 9/16	CHI-2240	8 11/16	CL-2715	6 7/8	CLI-3015	7 13/16
C2240	5 3/8	CH-2260	7 9/16	CHI-2420	3 1/2	CL-2720	9	CLI-3020	10 3/16
C2250	7 5/8	CH-2440	3 15/16	CHI-2425	4 5/16	CL-2725	11	CLI-3310	4 3/16
C2260	7 15/16	CH-2450	4 7/8	CHI-2430	4 3/4	CL-3015	4 3/4	CLI-3315	5 7/8
C2710	5 1/4	CH-2460	5 1/2	CHI-2440	6 3/16	CL-3020	6 1/16	CLI-3320	7 9/16
C2715	8 5/16	CH-2475	6 11/16	CHI-2450	7 5/8	CL-3025	7 5/16	CLI-3325	9 5/16
C2720	10 1/4	CH-2750	3 1/4	CHI-2460	9	CL-3030	8 5/8	CLI-3330	11
C2775	3 3/4	CH-2760	3 7/8	CHI-2740	4 3/8	CL-3040	11 5/8	CLI-4060	10 5/16
C3025	8 1/16	CH-2775	4 7/16	CHI-2750	5 1/8	CL-3320	4 11/16	CLI-4075	12 11/16
C3030	9 1/2	CH-27100	5 3/4	CHI-2760	6	CL-3325	5 9/16	CLI-40100	16 5/8
C3040	12 1/2	CH-3075	3 1/4	CHI-2775	7 1/4	CL-3330	6 3/8		
C3050	9	CH-30100	3 15/16	CHI-27100	9 3/8	CL-3340	8 9/16		
C3060	12 3/16			CHI-3060	4 1/8	CL-3350	10 7/16		
				CHI-3075	5 1/16	CL-3360	12 1/2		
				CHI-30100	6 7/16	CL-3660	8 5/8		
						CL-3675	10 5/8		
						CL-36100	13 3/4		
						CL-4060	6 1/8		
						CL-4075	7 1/2		
						CL-40100	9 11/16		

Wheel Balance

Airstreams containing particulate or chemicals can cause abrasion or corrosion of the fan parts. This wear is often uneven and can lead to significant wheel unbalance over time. When such wear is detected, a decision must be made as to whether to rebalance or replace the wheel.

The soundness of all parts should be determined if the original thickness of components is reduced. Ensure no hidden structural damage exists. The airstream components should also be cleaned to remove any build up of foreign material. Specialized equipment can be used to rebalance a cleaned wheel that is considered structurally sound.

Balance weights should be rigidly attached at a point that will not interfere with the housing or disrupt airflow. Remember that centrifugal forces can be extremely high at the outer radius of a fan wheel. Welding is the preferred method of balance weight attachment on steel wheels. Be sure to ground the welder directly to the fan wheel. Otherwise, the welding current could pass through the fan bearings and destroy them. Attach weights to aluminum wheels with bolts and self-locking nuts.



WARNING:

**WHEN USING A VARIABLE SPEED MOTOR DRIVE,
DO NOT EXCEED MOTOR NAME PLATE SPEED.
RUNNING FAN AT HIGHER SPEED THAN
RECOMMENDED MAY CAUSE CATASTROPHIC FAN
WHEEL FAILURE.**

Fan Rotation/Orientation

Fan rotation and orientation are determined by viewing the fan from the motor side.

Abbreviations: CW – Clockwise Rotation CCW – Counter Clockwise Rotation
 TH – Top Horizontal Discharge BH – Bottom Horizontal Discharge
 UB – Upblast Discharge DB – Downblast Discharge

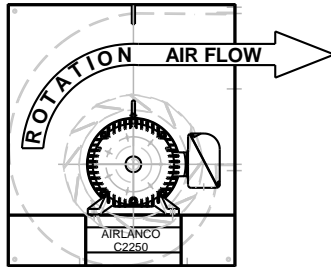

CW-TH

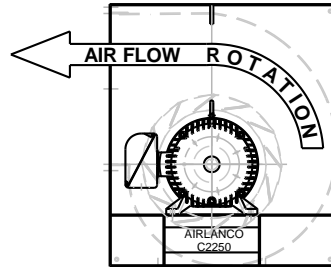

CCW-TH

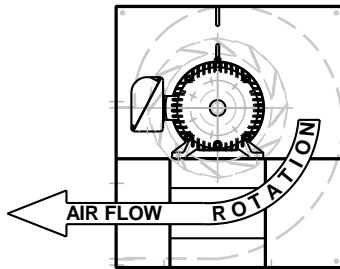

CW-BH

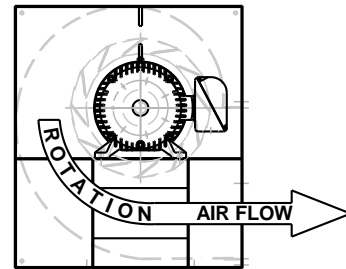

CCW-BH

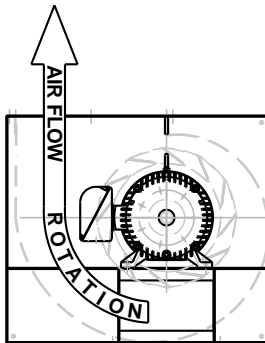

CW-UB

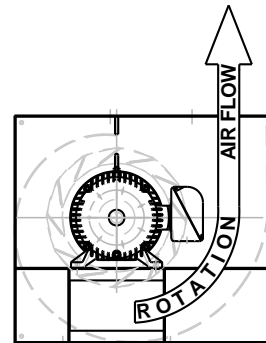

CCW-UB

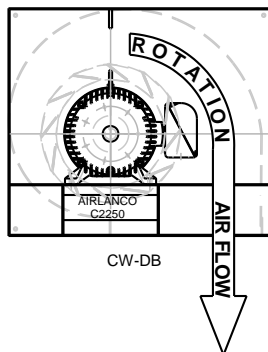

CW-DB

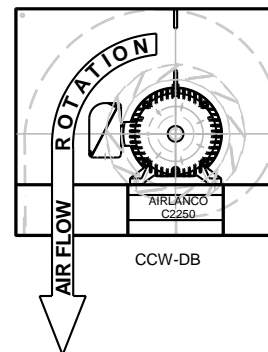

CCW-DB

Common Fan Problems

Excessive Vibration

A common complaint regarding industrial fans is “excessive vibration.” AIRLANCO is careful to ensure that each fan is precisely balanced prior to shipment; however, there are many other causes of fan vibration including:

1. Loose mounting bolts.
2. Misaligned or unbalanced motor.
3. Accumulation of foreign material on the wheel.
4. Excessive wear or erosion of the wheel.
5. Excessive system pressure or restriction of airflow due to closed dampers.
- 6. Inadequate structural support, mounting procedures or materials.**
7. Externally transmitted vibration.

Inadequate Performance

1. Incorrect testing procedures or calculations.
2. Fan wheel rotating in wrong direction or installed backwards on shaft.
3. Wheel not properly centered relative to inlet cone.
4. Damaged diverter.
5. Closed dampers or air leaks.
6. Obstructions or sharp elbows near inlets.
7. Sharp deflection of airstream at fan outlet.

Excessive Noise

1. Fan operating near “stall” due to incorrect system design or installation.
2. Vibration originating elsewhere in the system.
3. System resonance or pulsation.
4. Improper location or orientation of fan intake and discharge.
5. Inadequate or faulty design of supporting structures.
6. Nearby sound reflecting surfaces.
7. Loose accessories or components.
8. Worn motor bearings.

Premature Component Failure

1. Prolonged or major vibration.
2. Inadequate or improper maintenance.
3. Abrasive or corrosive elements in the airstream or surrounding environment.
4. Misalignment or physical damage to rotating components or bearings.
- 5. Bearing failure from incorrect or contaminated lubricant, or grounding through the motor bearings while arc welding.**
6. Excessive fan speed when fan is connected to aftermarket inverter control.
7. Extreme ambient or airstream temperatures.
8. Improper tightening of wheel bushing bolts may cause hubs to crack.

Replacement Parts

AIRLANCO recommends that only factory-supplied replacement parts be used. AIRLANCO fan parts are built to be fully compatible with the original fan, using specific alloys and tolerances. Replacement parts carry a standard AIRLANCO warranty.

Call AIRLANCO at 800-500-9777 to order replacement parts. Please have the following information available:

- ✓ Part name
- ✓ AIRLANCO serial number
- ✓ Fan size
- ✓ Fan type
- ✓ Fan orientation



All of this information is on the metal nameplate attached to the fan.

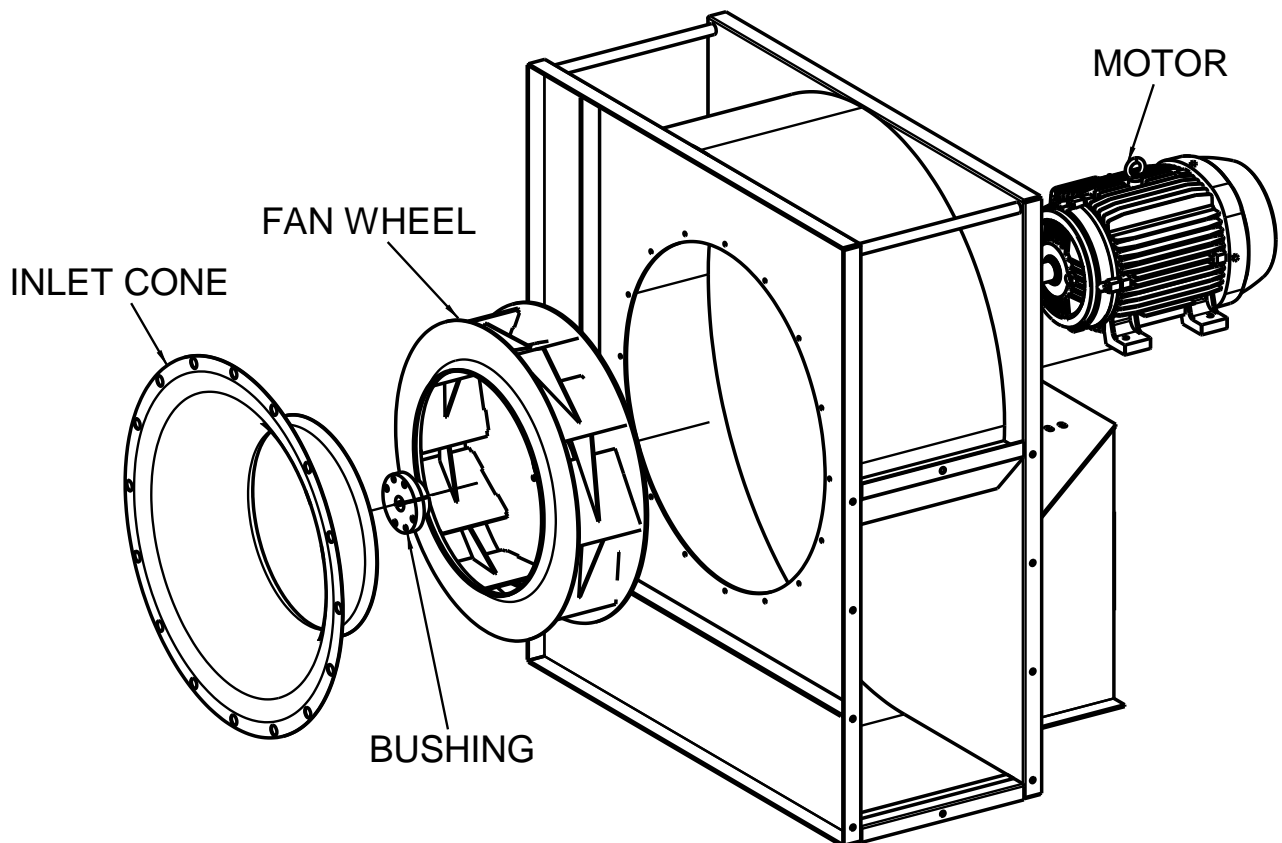

Warranty

The property sold hereunder is warranted for two full years against defective workmanship or materials. Such warranty is expressly limited to replacing or repairing any property sold hereunder, which is demonstrated to seller's reasonable satisfaction to have been defective at the time of delivery thereof. The liability of the seller for defective goods sold under this warranty is hereby expressly limited to the cost of the repairs to alterations of, corrections on, or replacement of said defective property and no other claims or demands whatsoever shall be made upon or required to be allowed by the seller. Seller shall not, however, be liable for any charges for repairs, alterations, corrections or replacement of the property as set out above, unless it has first received written notice from the buyer of any alleged defect and had a reasonable opportunity to inspect same. In no event shall seller's liability, exceed such specific direct costs for labor, materials and transportation to repair, alter, correct, or replace said defective property as it shall have previously been approved in writing. Seller shall not be liable for any special, indirect, or consequential damages.

Seller will use all reasonable means to deliver within the time specified, but shall not be held responsible or liable for any loss, damage, detention or delay caused by accidents, strikes, lockouts, fire, explosions, theft, lightning, windstorm, earthquake, floods, storms, riots, civil commotion, malicious mischief, act of God or by any other cause beyond its reasonable control whether or not the same is herein specified and in any event, seller shall not be liable for any special, indirect or consequential damages arising therefrom.

This warranty is expressly accepted by the buyer in lieu of any or all other warranties or representations, express or implied, in fact or in law arising out of the sale of the property and of all duties or liabilities of seller to the buyer arising out of the use of the property sold; and no agreement or understanding varying or extending the same will be binding upon seller unless in writing and signed by a duly authorized officer of seller. All electrical equipment carries standard manufacturer's warranties.